

Spark Plugs

Removal and Installation

1. Remove the ignition coil-on-plugs. For additional information, refer to [Ignition Coil-On-Plug](#) in this section.
2. **NOTICE:** Only use hand tools when removing or installing the spark plugs, or damage may occur to the cylinder head or spark plug.

NOTE: Use compressed air to remove any foreign material from the spark plug well before removing the spark plugs.

NOTE: If an original spark plug is used, make sure it is installed in the same cylinder from which it was taken. New spark plugs can be used in any cylinder.

Remove the 8 spark plugs.

- To install, tighten to 18 Nm (159 lb-in).

3. Inspect the spark plugs. Install new spark plugs as necessary. For additional information, refer to [Section 303-00](#).
4. Adjust the spark plug gap as necessary.

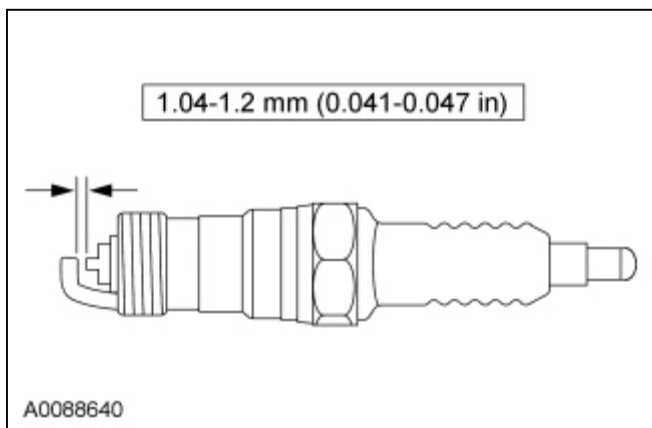

5. To install, reverse the removal procedure.
-

